

U.S.A.
2800 East 13th Street
Ames, IA
50010, USA
Phone: +1 515 239 6677
turollaocg@turollaocg.com

Italy
Via Natale Salieri, 33-35
40024 Castel San Pietro Terme,
Bologna, Italy
Phone: +39 051 6054 411
turollaocg@turollaocg.com

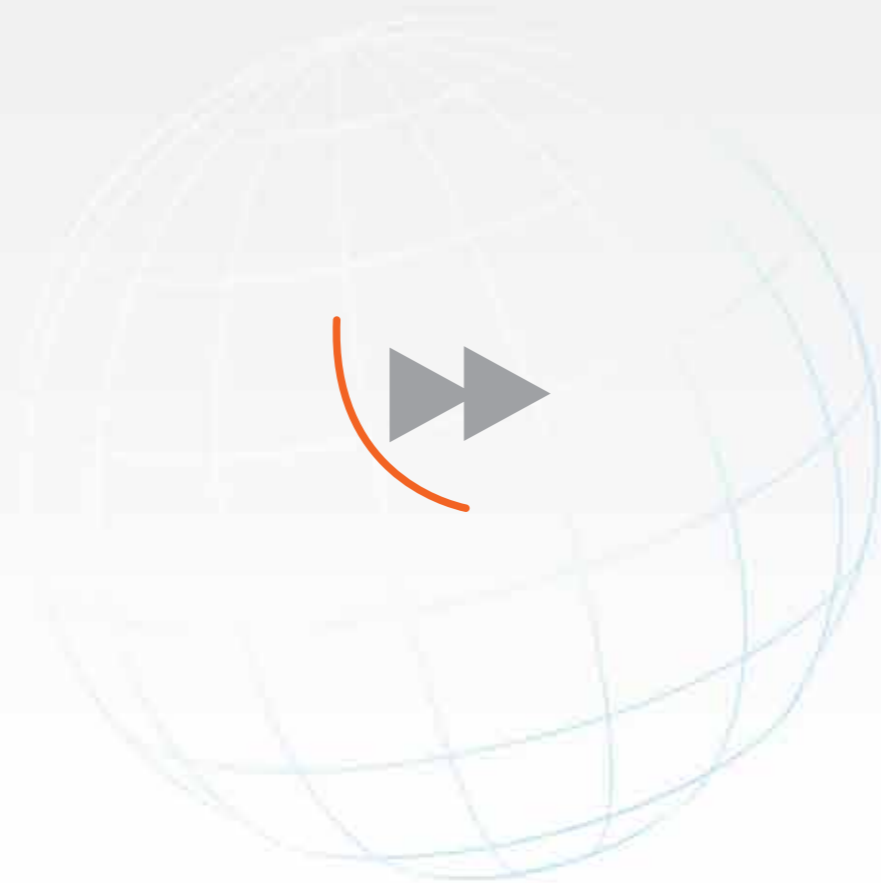

shhark 
when less is more

Turolla *shhark*[®]

We help you to take a big bite of the market!

Environment is not only clean air, green grass, fresh water and what you can see and smell. It is also sound and noise. In many of the machines using hydraulics today, it is desirable to lower the noise.

One way of doing this is to use a Turolla *shhark*[®] pump.

Turolla *shhark*[®]

With a simple yet sophisticated design, we offer a new gear pump that is not only quieter, but also has a unique advantage over the most popular low noise competitors.

Thanks to its revolutionary patented design, Turolla *shhark*[®] has almost twice the number of teeth of a standard gear machine of the same frame size. Moreover, through the further addition of a small helix angle, *shhark*[®] gears are able to reduce the flow pulsation by a stunning 78%.

The smooth flow characteristic of *shhark*[®] not only drops the noise emission of the pumps by 4 dB(A), but makes the whole hydraulic system quieter due to the reduced oscillations of all components, eliminating the need for expensive noise reduction devices.

Turolla decided not to rely on the popular "zero backlash" solution because we want to guarantee our customers a quiet and efficient product even after many hours of heavy duty operation in the field.

shhark[®] is therefore the gear pump to choose when low noise and high efficiency are required.

Typical applications include tractors, indoor lift trucks, aerial work platforms, construction equipment, material handling, agricultural machinery and lifting devices.

Turolla *shhark*[®] *continuum*[®]

Whenever total quietness is a need for your application, the Turolla *shhark*[®] *continuum*[®] is the product to choose. Designed with the ultimate goal of NoNoise, the *shhark*[®] *continuum*[®] can deliver an astonishing 15 dB(A) noise reduction thanks to the advanced gear technology.

The gear design drastically reduces the flow pulsation and vibration of the pump, avoiding pressure ripples that create noise. The external construction of the pump is very similar to regular gear pumps allowing for easy interchangeability on most of the machines.

The design of the *shhark*[®] *continuum*[®] relies on a sophisticated yet reliable balancing system. This design avoids gear wear while maintaining overall product efficiency.

Thanks to the performance at low speed, efficiency and NoNoise characteristics, the *shhark*[®] *continuum*[®] is ideal for demanding applications in material handling, agriculture, construction and all applications where primary consideration must be given to environmental surroundings.

Thanks to the significant noise reduction, it's possible to reduce noise dampening equipment installed on the machines. By doing this, the system becomes not only less expensive but simpler to install, and frees up space in the surrounding engine area.

This is why we are proud to refer to the *shhark*[®] *continuum*[®] pump as NoNoise.

shhark[®]
when less is more

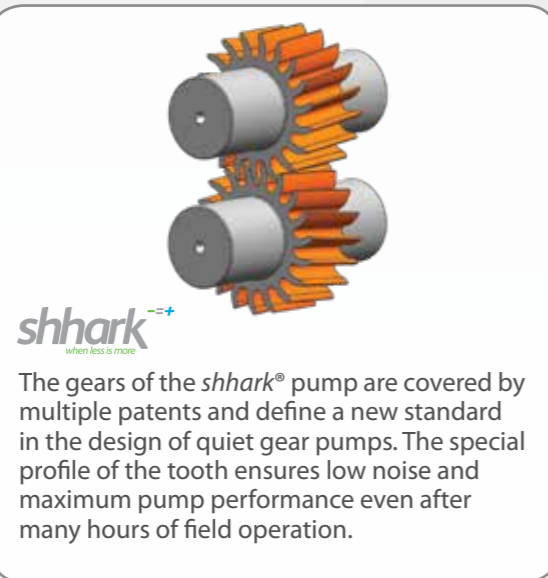

shhark[®]
when less is more

The gears of the *shhark*[®] pump are covered by multiple patents and define a new standard in the design of quiet gear pumps. The special profile of the tooth ensures low noise and maximum pump performance even after many hours of field operation.



shhark[®] *continuum*[®]
when less is more

The technology of the *shhark*[®] *continuum*[®] is hidden in the unique design of the gears. The permanent tooth contact ensures the fluid is transported smoothly with no trapped volume in between tooth flanks. Continuous tooth contact provides a silent and quiet operation. This unique patented design includes a state of the art compensation system that prevents wearing of the parts thanks to the flawless balancing of axial forces.

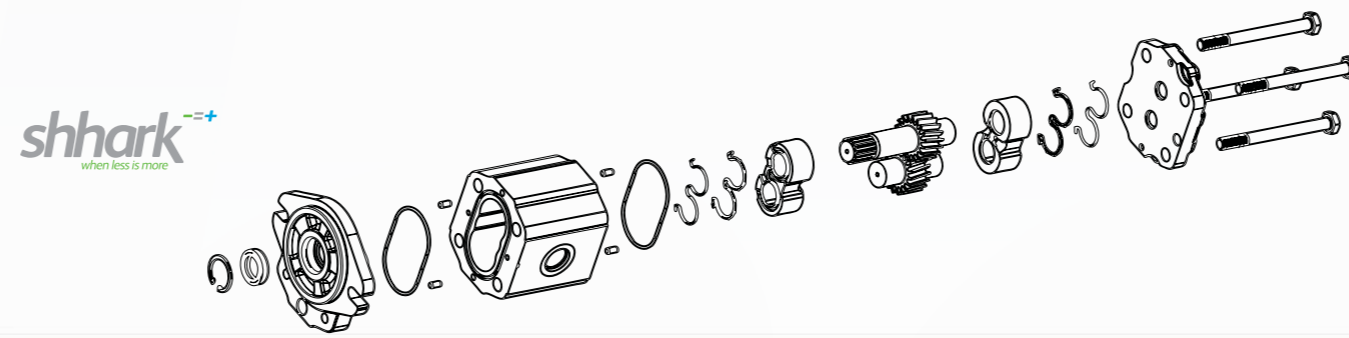

shhark[®]
when less is more

shhark [®]						
Size	Displacement cc/rev	Rated Pressure (bar)**	Minimum speed at 0-100 bar**	Minimum speed at 100-180 bar**	Minimum speed at 180 bar top rated pressure**	Maximum Speed (rpm)**
SHHP2	8 cc - 22 cc*	250	500	700	800	4000

shhark[®] Group 1, Group 3 and Cast Iron *shhark*[®] will be the further developments of our LoNoise product line. Stay tuned!

* 6,0 and 025 frame size are available upon request

** For details please see the *shhark*[®] catalog on-line at turollaocg.com

shhark [®] <i>continuum</i> [®]				
Size	Displacement cc/rev	Rated Pressure (bar)*	Minimum Speed (rpm)**	Maximum Speed (rpm)***
SHHCP28	4 cc - 13 cc	250	500	3500
SHHCP33	10 cc - 18 cc	250	500	3500
SHHCP38	16 cc - 28 cc	250	500	3000
SHHCP47	28 cc - 50 cc	250	500	3000
SHHCP55	50 cc - 90 cc	250	500	3000
SHHCP72	94 cc - 200 cc	240	500	1800

* Depending on size

** Depending on work condition

*** Depending on work condition and ports size

shhark[®] *continuum*[®]
when less is more

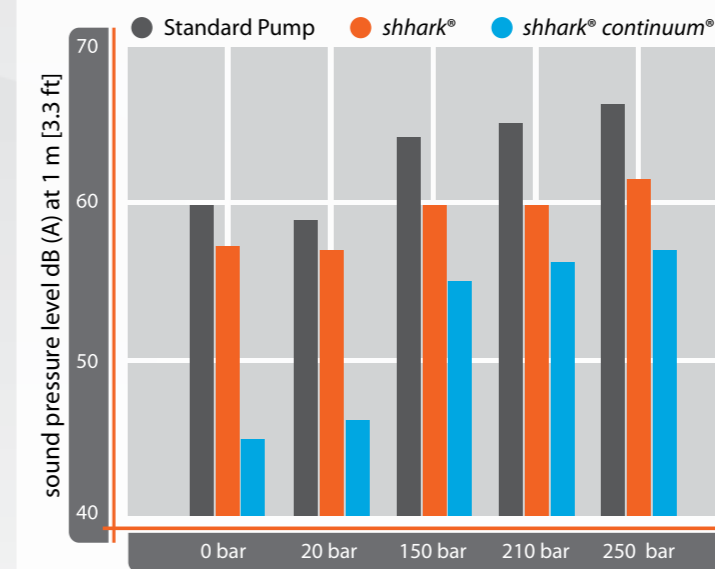
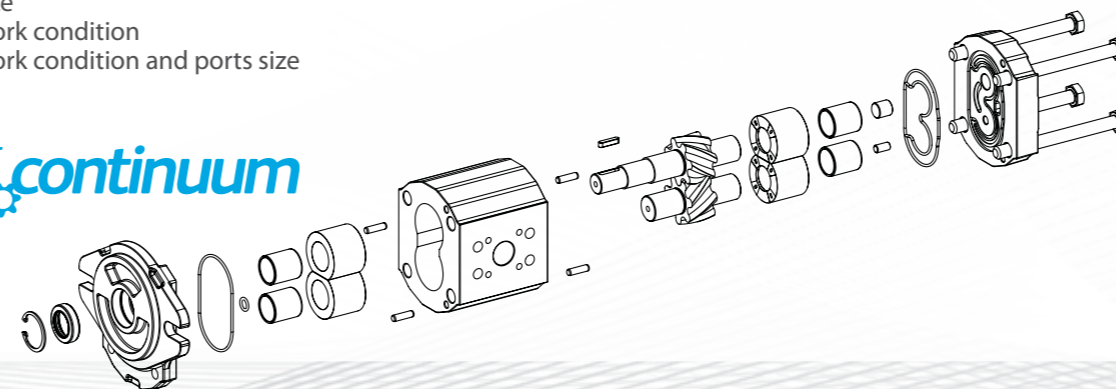

Listen carefully to our quiet technology

The graph shows the advantages of the *shhark*[®] line versus regular gear products. With Turolla *shhark*[®], the noise is reduced by 4 dB(A), with Turolla *shhark*[®] *continuum*[®] the noise is reduced by up to 15 dB(A).

Testing speed: 3000 rpm
Testing product: Group 2

Fast forward with Turolla

Turolla, a member of the Danfoss Group, is a global manufacturer and supplier of Gear Products and Fan Drive Systems. With a strong R&D and technical support network, Turolla can ensure first class responsiveness and reliable solutions. With more than 65 years of experience in developing and manufacturing Gear Products, Turolla is the right

global partner.

A lean process chain, from sales to product shipment, ensures that we are always offering the best solution to fit customers machines.

The Fast Lane[®] service enables us to provide all existing product configurations within a few days,

directly from the production line.

Turolla Fast Lane[®] service is currently available in both European and North American plants.

With the new *shhark*[®] line Turolla is keeping the promise to be ahead in our products offering, energy saving and new technologies.

shhark[®] bites your noise. Everywhere



TUROLLA
fast forward thinking